

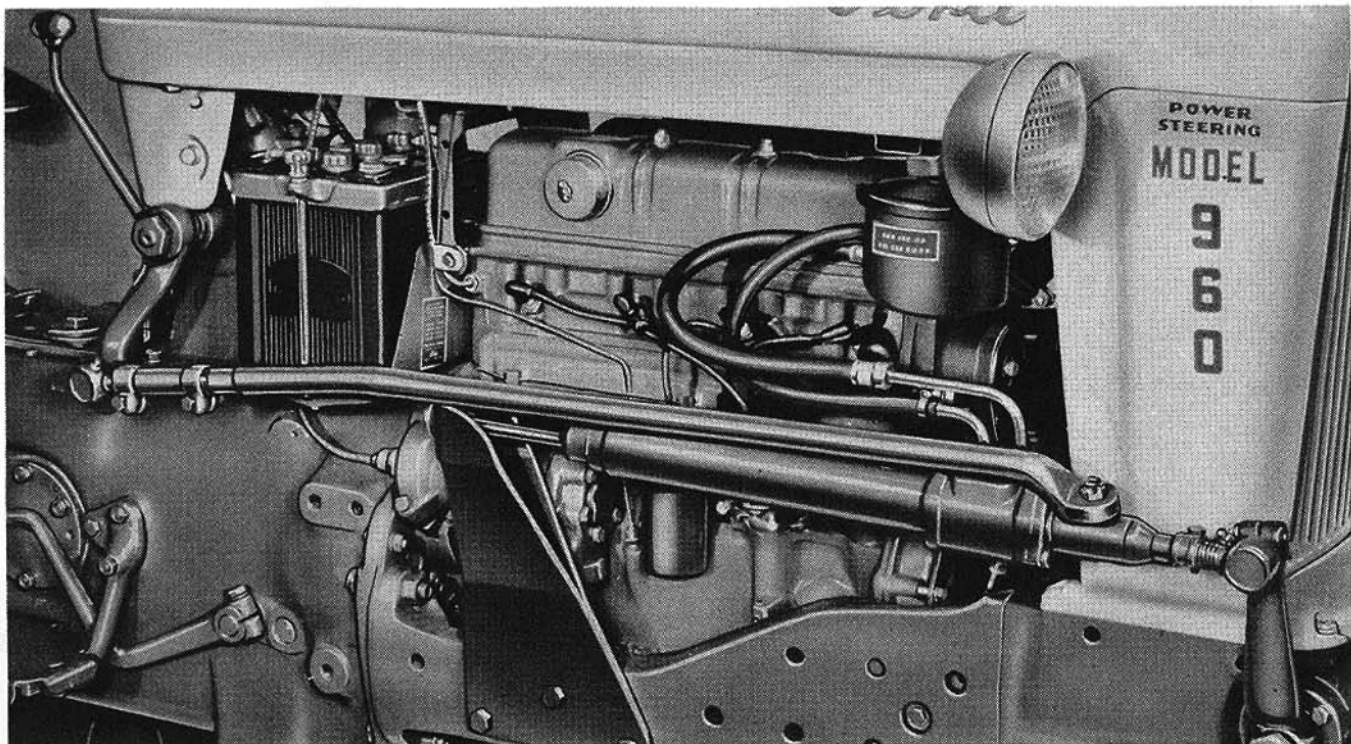

FORD
POWER STEERING KIT
(PART NO. 231118)



INSTALLATION INSTRUCTIONS



The Ford Power Steering Kit is a linkage type power steering system available for use on Series 700 and 900 Ford Tractors not so equipped. The system utilizes the conventional Ford Tractor steering gear and part of the linkage is replaced to provide a hydraulic power assist in all steering operations. In the event of power assist failure, the system provides a mechanical steering control which enables the tractor operator to exercise complete control of the steering system at all times.

The Ford Power Steering Kit consists of a rotor type pump and reservoir assembly with an integral combined flow control and relief valve, a double acting cylinder and control valve assembly, a two sheave crankshaft pulley and the connecting hoses and linkage.

The power steering pump is driven by a single V-belt from the two sheave crankshaft pulley. An integral flow control valve, located in the pump cover, limits oil flow to 2.75 G.P.M. with a maximum work-

ing pressure of 1100 P.S.I. as governed by the relief valve setting. This is sufficient to provide a power steering assist under all normal operating conditions. An oil filter located in the pump reservoir provides continuous filtering of the hydraulic fluid during system operation.

The power steering cylinder control valve is mechanically linked to the conventional steering gear of the tractor by means of a control valve assembly, which is activated by the drag link. Fluid from the pump is directed to either the rod or the piston end of the cylinder through internal passages in the control valve body to produce a right or left turn corresponding with the movement of the steering wheel. Fluid displaced by piston movement in the cylinder returns to the pump reservoir.

This manual contains information on the installation and general maintenance of the Ford Power Steering Kit. Read it carefully, study the illustrations and keep it available for ready reference.

Prepared by
TRACTOR AND IMPLEMENT DIVISION

Ford Motor Company

BIRMINGHAM, MICHIGAN

POWER STEERING

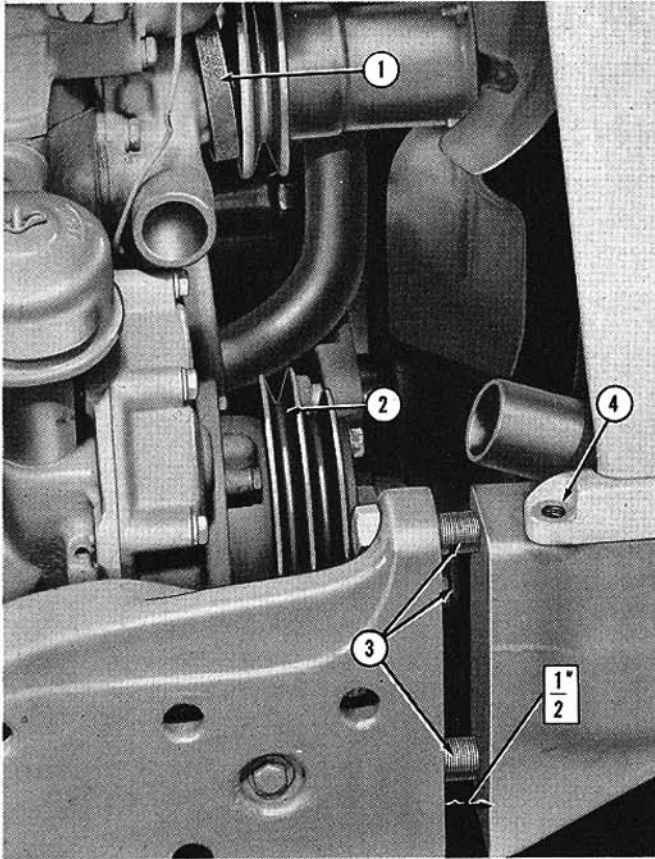

Figure 1
Two Sheave Pulley Installed

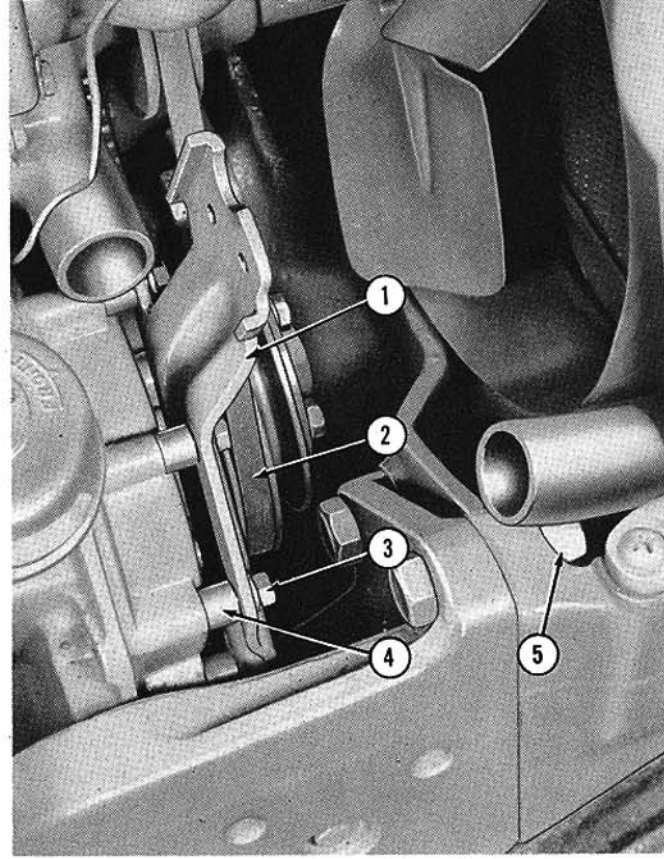

Figure 2
Lower Pump Support

SHIPPING INFORMATION

The Ford Power Steering Kit (No. 231118) is shipped in a single carton. Check the shipment against the following list to be sure that all parts are received.

Part Number	Item	Quantity
231103	Pump & Reservoir Assembly	1
231093	Support-Pump Upper	1
231095	Bracket-Pump Support	1
231098	Support-Pump Lower	1
231090	Spacer-Pump	3
231091	Spacer-Pump Support	4
231096	Hose-Pump Return	1
AD-22252-A	Clamp-Hose	1
231097	Hose-Pump Pressure	1
231201	Cylinder & Valve Assembly	1
AB-33642-B	Insulator	2
AB-33643-B	Washer-Insulator Outer	1
AB-33647-B	Washer-Insulator Inner	1
231099	Support-Cylinder	1
8N-3287	Clamp-Control Valve Sleeve	1
NCB-3305-A	Link-Drag	1
231092	Sleeve-Drag Link	1
TFAA-3287-A	Clamp-Drag Link	2

Part Number	Item	Quantity
NCB-3130-C	Arm-Front Steering	1
NCB-3590-C	Arm-Steering Pitman	1
231117	Pulley-Crankshaft	1
EAF-8577-A	Belt-Pump Drive	1
*231119	Spacer-Gang Lift Rod Arm	1
NCB-3649-A	Emblem—Power Steering Wheel	1
231206	Decal-Power Steering Identification	2
(SE 6337)	Installation Instructions	1
	Envelope containing standard miscellaneous parts	1

*A special Gang Lift Rod Arm Spacer, Part No. 231119, listed above is provided with each Power Steering Kit, to be installed on the Ford Front Mounted Cultivators when the tractor is equipped with power steering. This spacer should be installed between the Gang Rod Lift Arm, Part No. 131725 or Gang Chain Lift Arm, Part No. 133262 and the Gang Support Hanger, Part No. 131666. This will provide approximately 1" clearance between the cylinder and valve assembly and the inner gang lift rod arm when the gangs are raised.

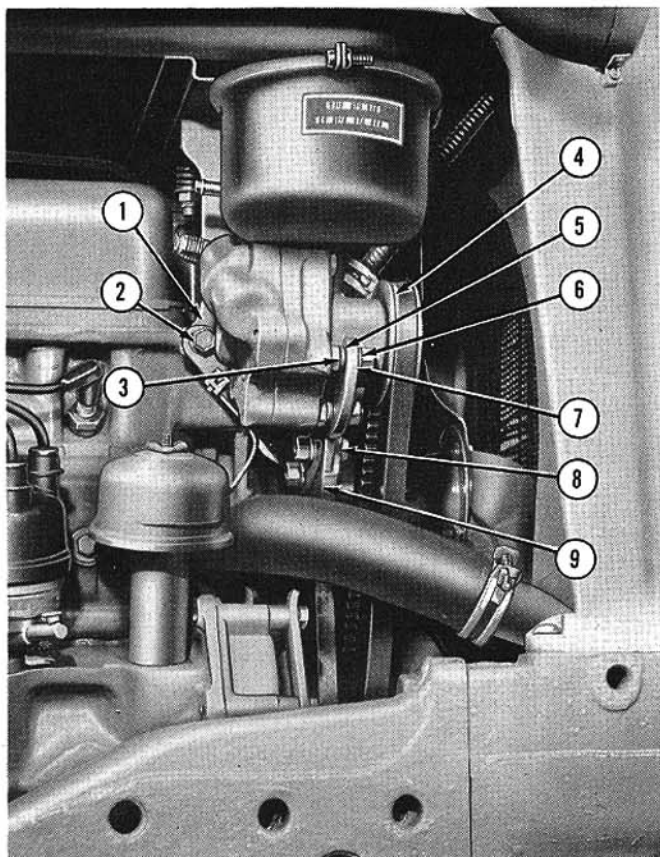

Figure 3
Pump Installation

INSTALLATION

Prior to installation of the Power Steering Kit, certain work must be done on the tractor as follows:

1. Drain tractor radiator by removing the drain plug. After the radiator has drained completely, replace the drain plug.
2. Remove and disassemble the conventional steering drag link as follows:
 - a. Remove cotter pin and slotted hex nut at the rear ball stud.
 - b. Loosen the clamps at the front and rear of the drag link. Remove the nuts and lockwashers from the steering spindle arms. Remove the hex head bolt and lockwasher which secures the front ball stud.
 - c. Disengage the drag link by tapping at front and rear ball studs with a soft nosed hammer. Unscrew the front and rear ball studs from the disengaged drag link. These studs should be retained for use during installation of the power steering system.
3. Remove the fan pulley dust shield, held by four capscrews and loosen the capscrew at the generator adjusting bracket. Remove lower radiator hose to gain access to the crankshaft pulley. Dis-

engage the fan belt from the crankshaft pulley and position as shown at (1), Figure 1.

4. Remove the conventional crankshaft pulley and hub held by four capscrews and the crankshaft bolt and flat washer.
5. Remove the radiator grille to facilitate movement of the pedestal and remove the four Philips head screws (4), Figure 1, which hold the side panels to the pedestal.

Installing the Two Sheave Pulley

NOTE: On tractors not so equipped it will be necessary to install the Two Sheave Pulley as outlined below. Tractors manufactured after Serial No. 77446 are already equipped with this pulley.

1. Position a floor jack to raise the tractor high enough to take the weight off of front wheels.
2. Remove the six nuts from the pedestal to side rail bolts (3), Figure 1, and move the pedestal forward $\frac{1}{2}$ " as shown, to provide installation clearance for the two sheave pulley as follows:
 - a. Install the new pulley (2), Figure 1, as shown, along with the conventional hub, using the four new $\frac{5}{16}$ -14 x $\frac{3}{4}$ " hex head bolts provided. Reinstall the crankshaft bolt and flat washer.
 - b. Return the pedestal to side rails and install the six nuts (5), Figure 2, previously removed. Tighten the bolts securely.
 - c. Install the four Philips head screws which hold the hood side panels to pedestal and install the radiator grille with four wing nuts. Remove the floor jack.
 - d. Install the fan belt (2), Figure 2, as shown on larger sheave of the new pulley and adjust to proper tension at the generator bracket. Tighten the bracket capscrew securely.

Installing the Pump

1. Remove the tractor head light wire clip from the heat deflector plate, and remove the heat deflector from the front gas tank bracket by cutting the spot welds with a hammer and chisel.
2. Remove the four capscrews and lockwashers from the timing gear cover.
3. Install the pump with the brackets provided as follows:
 - a. Attach the lower pump support (1), Figure 2, to the timing gear cover as shown, using four $\frac{5}{16}$ -18 x $2\frac{1}{2}$ " hex head bolts (3), and four $\frac{1}{2}$ " spacers (4), provided.
 - b. Attach the upper pump support (5), Figure 3, to the pump assembly, using three $\frac{3}{8}$ -24 hex nuts (6), pump spacers (3), and $\frac{3}{8}$ " lockwashers (7).
 - c. Remove the capscrew, located at (2), Figure 3, which secures the front fuel tank support to the cylinder head.

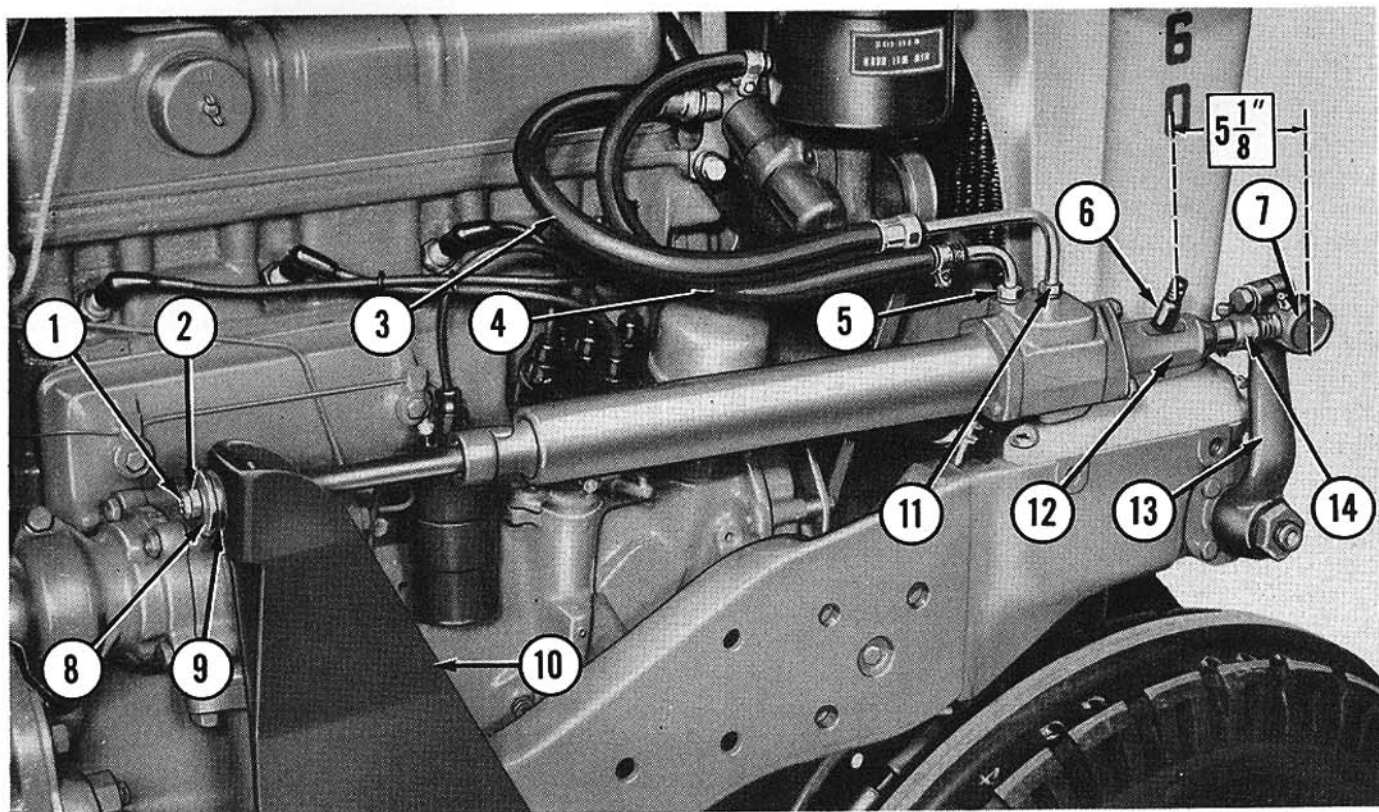

Figure 4
Attaching Cylinder & Valve Assembly

- d. Position the pump and reservoir assembly with attached upper support (5), Figure 3, to the lower support (9), as shown. Position the pump support bracket (1), to align the mounting holes with the cylinder head at (2), and lower the pump support (9).
- e. Attach the pump support bracket (1), Figure 3, to the lower pump support (9), with two $\frac{3}{8}$ -24 x $1\frac{1}{8}$ " hex head bolts (8), two lockwashers and two $\frac{3}{8}$ -24 hex nuts provided. Do not tighten at this time. Secure the pump bracket to the cylinder head at (2), with one $\frac{3}{8}$ -16 x 1" hex head bolt and lockwasher.
- f. Adjust the pump assembly to its lowest position on the lower support and install the pump drive belt (4), Figure 3. Raise the pump assembly to tighten the belt to a tension of $\frac{1}{4}$ " deflection (under 5-7 lbs. thumb force) at belt center. When correct belt tension is obtained, tighten the pump bracket to lower pump support bolts securely.
- g. Install the lower radiator hose. Make sure that there is $\frac{1}{2}$ " clearance between the hose and the pump drive belt.
- h. Reinstall the fan pulley dust shield using the four capscrews and lockwashers. Fill the cooling system with the proper coolant.

- i. Install the head light wire clip and wire on the pump bracket as shown in Figure 3.

Installing the Cylinder and Valve

1. Turn the tractor front wheels to the straight ahead position. Note the position of the front steering arm. Remove the hex nut, and lockwasher and pull the arm from the steering gear sector shaft using a standard gear puller if necessary.
2. Install the new front steering arm (13), Figure 4, in a vertical position on the steering gear sector shaft by aligning the blank teeth. Install the lockwasher and hex nut and tighten securely.
3. Remove the standard Pitman steering arm and install the new Pitman steering arm as follows:
 - a. Turn the steering wheel until it engages the stops. Then center the wheel for straight ahead driving position, which should be approximately $3\frac{1}{8}$ revolutions.
 - b. Install the new Pitman steering arm on the steering sector shaft as shown at (4), Figure 5, so that the mark on the arm aligns with the center of the blank teeth at the top of the sector shaft.
4. Install the cylinder support (10), Figure 4, in the position shown on the R.H. side rail with three $\frac{5}{8}$ -18 x $1\frac{1}{2}$ " hex bolts and three $\frac{5}{16}$ -18 square nuts.
5. Install the cylinder and valve assembly as follows:

POWER STEERING

- a. Install the clamp (14), Figure 4, on the outer sleeve assembly of the cylinder. Install a $\frac{5}{16}$ -24 x $1\frac{1}{16}$ " carriage bolt in the clamp with lockwasher and nut. Do not tighten at this time.
- b. Assemble the front ball stud partially into the outer sleeve (12), Figure 4, of the cylinder and valve assembly.

CAUTION: Do not screw the stud all the way into the outer sleeve as the stud may bottom against the ball stud retainer and seriously hamper control valve actuation. Proper adjustments can be made after installation is completed.

- c. Install the inner insulator washer (6), Figure 5, on the rod end of the cylinder assembly so that it bears against the shoulder on the rod. Install the rubber insulator (5), Figure 5, on the rod end so that it bears against the inner insulator washer.

NOTE: The outer insulator washer has an I.D. of .464 - .474 and the inner insulator washer has an I.D. of .515 - .525.

- d. Jack the tractor sufficiently high to free the front wheels and align the front steering arm vertically as shown at (13), Figure 4.

- e. Install the cylinder and valve assembly by inserting the front ball stud into the front steering arm as shown at (7), Figure 4. Replace the bolt and lockwasher in the front steering arm and tighten. Position the cylinder rod through the hole provided in the cylinder support (10). Install the insulator (9), and outer insulator washer (8), to the end of the rod as shown. Secure with the $\frac{7}{16}$ -20 hex jam nut (2), and $\frac{7}{16}$ -20 hex stamped nut (1), provided. Tighten securely.
- f. Adjust the distance from the center of the cylinder control ball stud (6), to the center of the front ball stud (7), by rotating the cylinder and valve assembly. The distance between these centers should be $5\frac{1}{8}$ inches as shown in Figure 4. The face of the valve housing (containing the oil ports) should be on a horizontal plane when this measurement is made. Position clamp shown at (14) and tighten.

Installing the Oil Line Hoses

1. Install the pump return hose (4), Figure 4, to the pump reservoir at one end and to the rear port of

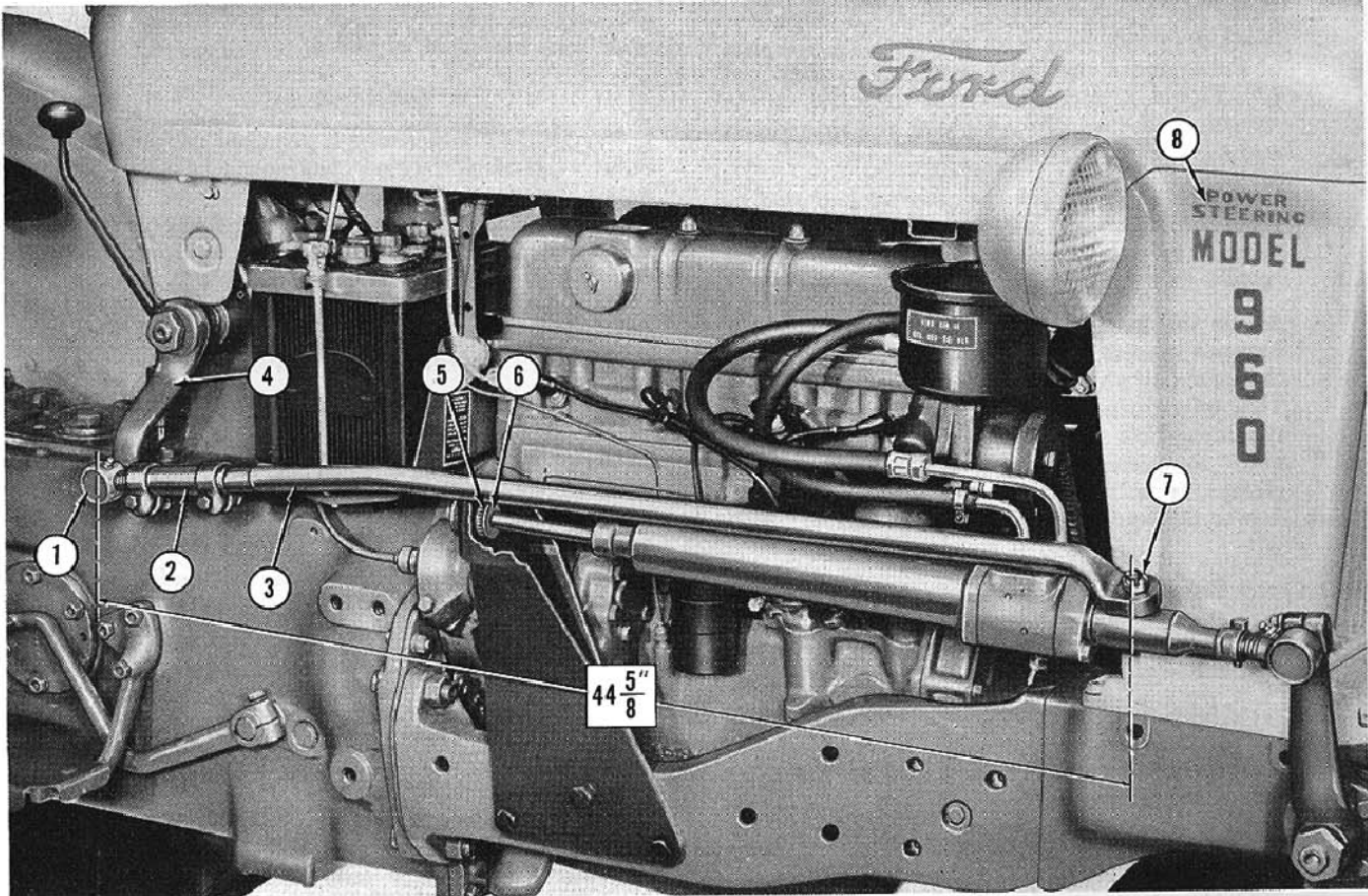

Figure 5
Attaching the Drag Link

POWER STEERING

the control valve shown at (5). Tighten the fitting at (5), and install the clamp at the pump end of hose as shown.

2. Install the pump pressure hose (3), to the pump pressure port and to the front port of the control valve as shown at (11). Tighten the fittings at each end of the hose.

CAUTION: Do not reverse the inlet and outlet hoses. If reversed, the power steering system will not operate properly.

Installing the Drag Link

1. Thread the sleeve (2), Figure 5, partially on the drag link (3), and assemble the two clamps on the sleeve as shown. Secure loosely with two $\frac{7}{16}$ -20 x $1\frac{7}{8}$ " hex head bolts, $\frac{7}{16}$ " lockwashers and $\frac{7}{16}$ -20 hex nuts.
2. Thread the conventional rear ball stud (1), partially into the opposite end of the drag link sleeve.
3. Install the new drag link as follows:
 - a. Connect the adjustable end of the drag link to the Pitman steering arm as shown at (1), Figure 5, and secure in position with the conventional lockwasher, castellated nut and cotter pin.
 - b. Turn the tractor steering wheel to align the front drag link hole with the steering ball stud of the cylinder and valve assembly as shown at (7), Figure 5, and connect the drag link to the steering ball stud using a $\frac{1}{2}$ -20 hex slotted nut and $\frac{1}{8}$ x 1" cotter pin.

CAUTION: Do not cock the steering ball stud to make the necessary alignment with the front drag link hole. The steering ball stud should remain in a vertical position.

- c. Adjust the assembled drag link length to $4\frac{45}{8}$ " between centers of the steering ball stud at (7), and rear ball stud at (1), as shown in Figure 5. This adjustment is made by turning the screw type drag link sleeve (2). After adjustment has been completed, secure the two drag link clamps in position as shown in Figure 5.
- d. Lower the tractor and remove the jack.

Installing Power Steering Emblem and Decals

1. Remove the steering wheel nut and flat washer. Discard the washer.

NOTE: Check alignment of the steering wheel spokes for straight ahead driving. If necessary, reposition the steering wheel one notch on the shaft to correct the alignment.

2. Install the metal power steering emblem (flat disc) under the steering wheel nut.
3. Position the power steering decals on the left and right hood side panels, above the word "Model" as shown at (8), Figure 5.

Filling the Pump Reservoir

1. Turn the tractor wheels to the left against the stops. In this position the piston will be retracted in the cylinder.
2. Remove the reservoir cover by turning the screw outward to loosen the cover retaining clamp.
3. Fill the reservoir to within $\frac{1}{2}$ " of the top with Automatic Transmission Fluid—Type A and replace the cover. Start the tractor engine. Do not accelerate. Maintain normal idle engine speed.
4. Operate the power steering system by slowly turning the steering wheel from one extreme position to the opposite extreme position. Do not hold against stops.
5. Repeat the steering cycle until system is free of air. This can be noted by observing the fluid in the reservoir for turbulence during steering action. Operate the system until turbulence ceases.
6. Turn the tractor wheels to the left and stop the tractor engine. Refill the reservoir to within $\frac{1}{2}$ " of the top. Replace the cover and secure with the cover clamp.

Adjustments

The Ford Power Steering System is a closed system and requires no adjustments other than maintaining the original adjustment dimensions of the drag link and front ball stud as noted during installation.

Maintenance

Very little maintenance is required to keep the Ford Power Steering System operating properly. When major overhauls become necessary, see your Ford Tractor and Implement Dealer. He is interested in you and your tractor, and is properly equipped to meet your service needs.

Daily and periodic maintenance is given as follows:

System Hydraulic Fluid

1. Always use Automatic Transmission Fluid—Type A in the system.
2. After initial filling of the system, maintain a constant oil level ($\frac{1}{2}$ " from the top) in the pump reservoir.
3. Use only clean fluid to replenish the system.
4. Make frequent checks of the hydraulic hose connections to avoid oil leakage or intake of air into the system.
5. The filter element, located in the reservoir, need not be replaced under normal operating conditions and does not require servicing.

LUBRICATION

The Ford Power Steering System has only one grease fitting located in the sleeve and flange assembly. Lubricate this fitting every ten hours of operation with pressure gun grease. The pump, cylinder and valve assembly are internally lubricated by the system fluid and require no external lubrication.